

LIQUID FREEZER

TOMIN



LIQUID FREEZER

TOMIN

Hyper-Freezing

The revolutionary super fast liquid freezing system by TECHNIGAN
TOMIN Liquid Freezers



Air blasting creates ice crystals that are 100 to 200 microns in diameter, whereas the cells in meat and fish are only 20 to 30 microns in diameter.

With conventional freezing methods products are subjected to very cold air in a process known as air blasting. This system is widely used by manufacturers of household freezers and its ease of use has gained it broad acceptance. Notwithstanding its widespread popularity, the quality of the products frozen in this manner is inferior to fresh goods. It is a recognized fact that air blasting creates macro-crystals that damage the cells in meats and fish, which cause loss of nutritional value and organoleptic qualities of the product.

Liquid freezing ice crystals are only 5 microns in diameter.

In recent years, the increased dissemination of information throughout society has brought demands from consumers for lower prices and higher quality for all manners of commodities. The days of having to sacrifice quality for lower prices is over. Technican Co., Ltd. manufactures the revolutionary TOMIN Liquid Freezers that defines the new standards in freezing.

Freezing with absolutely no organoleptic variations to the product.

This is achieved by dispelling the preconception that freezing can only be accomplished by exposure to cold air. Technican utilizes the properties of **cold fluids to freeze product** in a process called the TOMIN Liquid Freezer Method.

This fast freezing method leads to the formation of micro-ice crystals of only 5 microns in size, avoiding damage to food molecules. After defrosting, the product is restored to its pre-frozen state of freshness with no loss of liquids, color, firmness or flavor.

We have received patents for our innovative Liquid Freezer system in Japan, Europe, Asia, Oceania and other regions of the world.

TOMIN'S Problem-Solving Advantage

AIR

■ **Low thermal conductivity**

Damage from macro-ice crystals at the cellular level and bacterial proliferation due to the time taken in freezing.

■ **Dripping during defrosting**

Large loss of liquids, firmness and flavor from food.

■ **Declining quality**

Loss of nutritional value and organoleptic qualities.

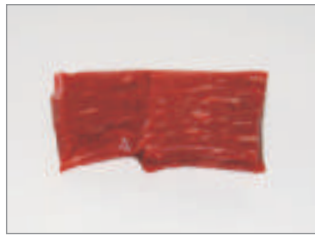

Air-blast freezing

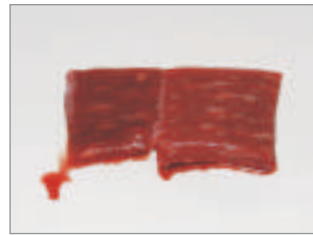

After defrosting from air-blast freezing

LIQUID



Liquid freezing



After defrosting from liquid freezing

■ **20 times better thermal conductivity**

The thermal conductivity of the liquid yields a 20-fold increase in freezing speed the speed needed to obtain micro-crystallization and avoid cellular damage.

■ **Minimal drip**

TOMIN maintains freshness and moisture, without loss of flavor or juices.

■ **Higher quality**

Incredible results in all facets of food quality: taste, texture, color and fragrance.

■ **Space saving**

The space required for a TOMIN unit is 1/6 or less than a conventional freezer.

■ **Improved working environment**

TOMIN reduces the strain on workers by eliminating the need to work in a refrigerated environment.

■ **Simple operation**

Freezing is easily accomplished by a simple touch of the button.

■ **Applications for diverse products and industries**

Besides the freezing of meat, poultry and seafood, TOMIN is suitable for freezing a broad range of food-stuff such as processed foods, pre-leavened products and prepared foods.

■ **Long shelf life**

Powerful & versatile freezing extends the shelf life of food and makes it possible for long-term storage, and better stock management.

■ **No special defrosting requirements**

Defrosting can be carried out at any temperature with no other special requirements.

Technician freezing fluids safety features

1. The ethanol contained in the freezing fluids are a volatile material, but at temperatures below -8°C to -10°C, volatility is reduced and no evaporation occurs.
2. The freezing fluids do not form "sherbet" ice slurry above -41°C.
3. The flash point of the freezing fluids is approximately 24°C (by external application of a direct flame, etc.).
4. If the unit is idle for a long time, it will automatically maintain the temperature at -10°C to -15°C in order to hibernate the freezing fluids and minimize the freezer running cycle.

Examples of TOMIN Liquid Freezer Applications—Retail

● Pubs and inns

Fish roe from seasonal catches like salmon can be frozen in bulk with no loss of shape or texture after defrosting. Japanese delicacies such as whipped *yamaimo* (yam) and similar foods can be frozen and defrosted in portions as needed.

● Korean barbecue restaurants

Time consuming preparation dishes such as Korean *Yukhoe* can now be made in advance and frozen. By defrosting on demand, restaurants can offer this spicy delicacy whenever they wish while making more efficient use of their time.

● Hotels and restaurants

Customers can be offered short-shelf life appetizers such as sashimi (sliced raw fish) and crab with "newly-caught" freshness and flavor. TOMIN Liquid Freezer is also ideal for previously un-freezable delicacies such as *terrine* and *foie gras*.

● Shabu-shabu restaurants

Frozen thinly sliced meats served in *shabu-shabu* restaurants retain their juices and flavor through minimal dripping.

● Supermarket delicatessens

Tempering (freezing the surface layer of ham, meat, etc. for easier slicing) can be quickly and easily achieved using a TOMIN Liquid Freezer. This process reduces meat wastage during slicing and the product is not prone to temperature rises after packing in trays, which helps retain flavor.

In addition, the TOMIN Liquid Freezer can be deployed in an array of businesses, including marine product and meat processing plants.

Examples of TOMIN Liquid Freezer Applications-Foods

Meat	Fish	Other seafoods	Vegetables and fruit	Processed and prepared foods
Beef	Salmon	<i>Ankimo</i> (monkfish liver)	Bamboo shoots (boiled)	Vacuum-cooked foods
Pork	<i>Fugu</i> (blowfish)	Octopus	<i>Gobo</i> (burdock root)	Prepared meals
Chicken	Tuna	Shellfish	Broccoli	Thick omelets
Offal	Sea-bream	Abalone	Wild vegetables	Roast beef
<i>Foie gras</i>	<i>Aji</i> (horse mackerel)	Salmon roe	Mango	Seasoned fish
	<i>Hirame</i> (flounder)	Caviar	Papaya	Chinese food
Ham (tempering)	<i>Anko</i> (angler fish)	Squid	<i>Yama-imo</i> (yam)	Catering ingredients

TOMIN Liquid Freezer Freezing Time Guidelines

Food Thickness	Beef, tuna	Pork, chicken, liver	White fish	Bamboo shoots (boiled)	Salmon	Ham, salmon roe (high-salt content foods)
2cm	8—10	10—12	8—10	7—9	10—12	12—13
5cm	40—50	40—50	40—50	35—45	40—50	45—65
8cm	60—80	70—90	60—80	50—60	70—90	80—90
10cm	70—90	80—100	70—90	60—70	100—120	100—120

(Units: minutes)

TOMIN Liquid Freezer - Power Consumption

The freezer incorporates a cost-savings thermostat feature which automatically hibernates the system after reaching a pre-set temperature.

Note: Figures based on full operation of eight hours per day, 30 days per month.

Daily (eight hours) power
consumption

JPY **79**
(for a 1 kW freezer)

Monthly (30 days) power
consumption

JPY **2,730**
(for a 1 kW freezer)

Overall Comparison of Freezer Systems

Freezing method	Advantages
	Disadvantages
TOMIN Liquid Freezer (Liquid freezing)	<ul style="list-style-type: none"> • Enables optimum quality freezing • No dripping • No cold environment manual work and easy operation
	<ul style="list-style-type: none"> • Packing needed to allow immersion in alcohol solution
General freezers (Air blast)	<ul style="list-style-type: none"> • Broad application, from commercial to residential use • Easy to use • Inexpensive
	<ul style="list-style-type: none"> • Longer freezing time required • Dripping, resulting in deterioration in freshness and flavor • Poor yield
Marine refrigeration (Ultra-low temperature storage)	<ul style="list-style-type: none"> • Ultra-low temperatures, facilitating high quality freezing than general Air blast methods • Enables freezing of bulky objects (eg. tuna)
	<ul style="list-style-type: none"> • Restrictions on use and location
Dry ice (Gas freezing)	<ul style="list-style-type: none"> • As with ultra-low temperature air blast freezing, high freezing speed enables high quality freezing
	<ul style="list-style-type: none"> • Degassing required after freeze treatment when freezing without packing • Dry ice cost incurred for each freeze operation • Dry ice storage facilities required
Nitrogen (Nitrogen gas freezing)	<ul style="list-style-type: none"> • Facilitates high quality freezing
	<ul style="list-style-type: none"> • Higher running costs • Possibility of cracking of products more than 12 mm in thickness

Temperature and Storage Guidelines

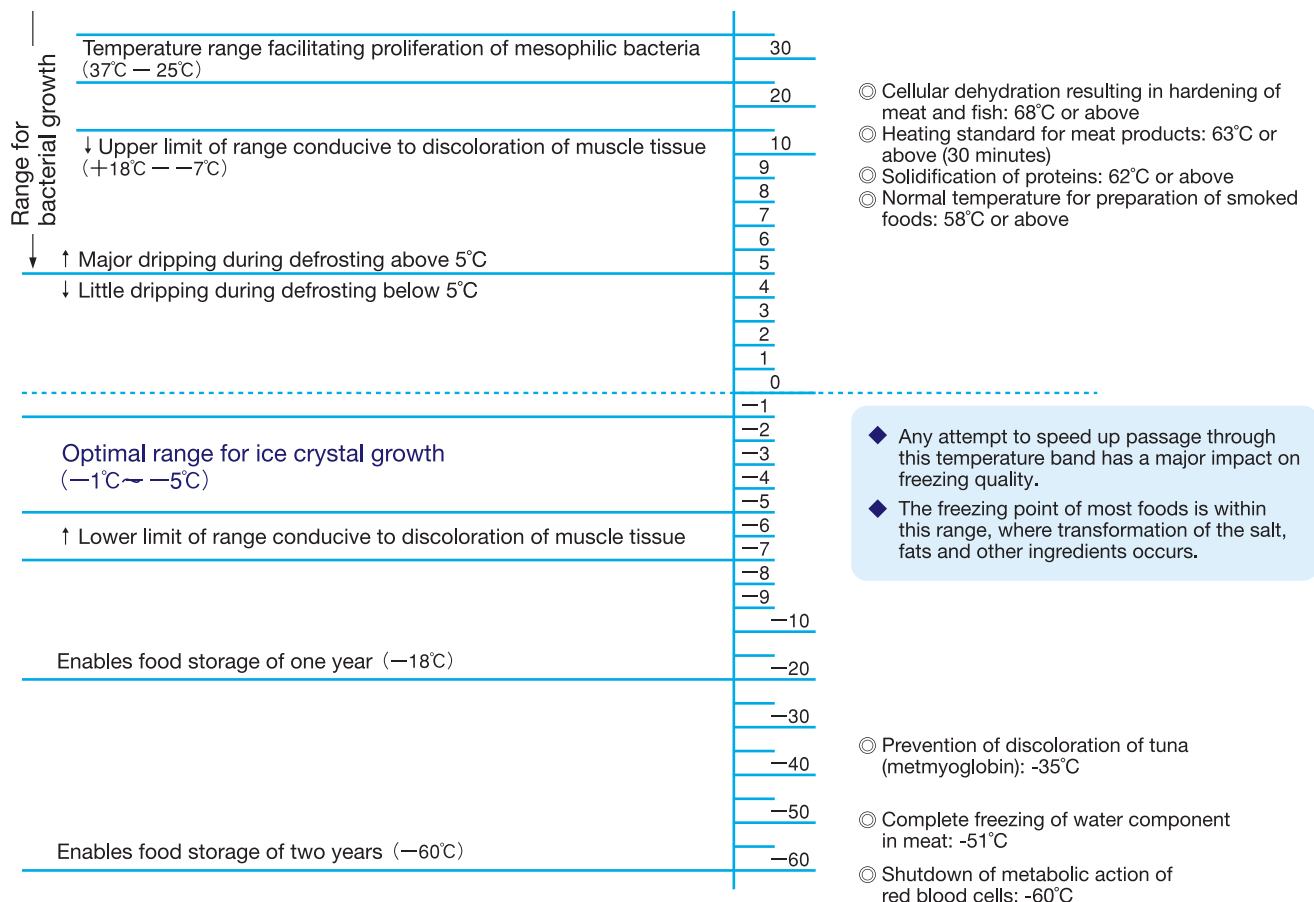

Variation in Freezing Point with Secondary Refrigerant Concentration

Concentration Wet %	Calcium chloride (CaCl ₂)		Sodium chloride (NaCl)		Ethyl alcohol (C ₂ H ₅ OH)	
	Freezing point (°C)	Specific gravity (at 15°C)	Freezing point (°C)	Specific gravity (at 15°C)	Freezing point (°C)	Specific gravity (at 15°C)
5	-2.0	1.04	-3.4	1.04	-2.0	0.99
10	-5.4	1.08	-7.4	1.08	-4.5	0.98
15	-11.2	1.14	-12.8	1.11	-7.2	0.98
20	-17.4	1.18	-16.6	1.15	-11.0	0.97
23.1			-21.2	1.18		
25	-28.3	1.23	-9.5	1.19	-15.8	0.97
26.3			-0.0	1.20		
30	-55.0	1.29			-20.5	0.96
35	-15.6	1.34			-25.3	0.95
37.5	-0.0	1.37				
40					-30.5	0.94
50					-38.0	0.92
60					-43.5	0.90
70					-50.5	0.87
80					-67.0	0.85
90					-1130	0.82
100					-1140	0.79

TOMIN Specifications

Model	S-150W	LM-45	LM-75	TL-1G	TL-2G	TLB-1G	TLB-2G
Type	Small manual	Small lift	Medium lift	Large lift	Large lift	Extra large lift	Extra large lift
L(mm) of body	640	1100	1015	1300	1300	1650	1650
W(mm) of body	1140	1640	1555	1900	3450	2690	4750
D(mm) of body	1140	1840	2160	2160	2160	2425	2425
Body/Freezer	Integrated		Main body and Freezer are separated.				
Weight (approx)	180kg	850kg	900kg	1280kg	2000kg	1850kg	3200kg
Freezer type	Middle to low	Two stage scroll type of compression					
Freezer output	1.5KW	4.5KW	7.4KW	12.0KW	26.8KW	30KW	60KW
Condenser	Accelerated cooling stainless steel piping						
Capacity of Freezer (Kcal/h) -35°C, 50HZ	1040	4988	7112	11266	23908	24602	52804
With stand	non	non	non	1 set	2 sets	2 sets	4 sets
Tub	1	1	1	1	2	1	2
Basket in gondola (L×W×D)mm	(640×450×250) ×1	(700×500×500) ×1	(550×800×650) ×1	(850×1000×600) ×1	(850×1000×600) ×2 *1 basket in 1 tub.	(700×1000×650) ×2 *2 baskets in 1 tub.	(700×1000×650) ×4 *2 baskets in 1 tub.
*Capacity(kg/h) 50HZ, item:+5°C	18kg/hour	55kg/hour	85kg/hour	140kg/hour	300kg/hour	340kg/hour	680kg/hour
Total electric circuit (AC200V)	1.7KW	5.1KW	8.55KW	13.9KW	30.6KW	33.35KW	63.7KW
With Filter for *tempering	+ option 60-70kg/hour	+ option 230-270kg/hour	+ option 330-360kg/hour	+ option 520-610kg/hour	+ option —	+ option —	+ option —
Quantity of liquid	125 liters	440 liters	740 liters	1250 liters	2400 liters	2490 liters	4550 liters

* Note that each number is approximately. There is a difference in freezing capacity between 50HZ and 60HZ.

• Capacity(kg/hour): Amount that can freeze by one hour. The product before freeze within +5°C. Liquid temperature is -30°C, 50HZ, item:+5°C • With filter (circulator) type for Tempering (Pre-slicing surface condensation for ham, smoked salmon etc). • There are other models except the above-mentioned.

Main body + Freezer <Integrated type>

S-150W

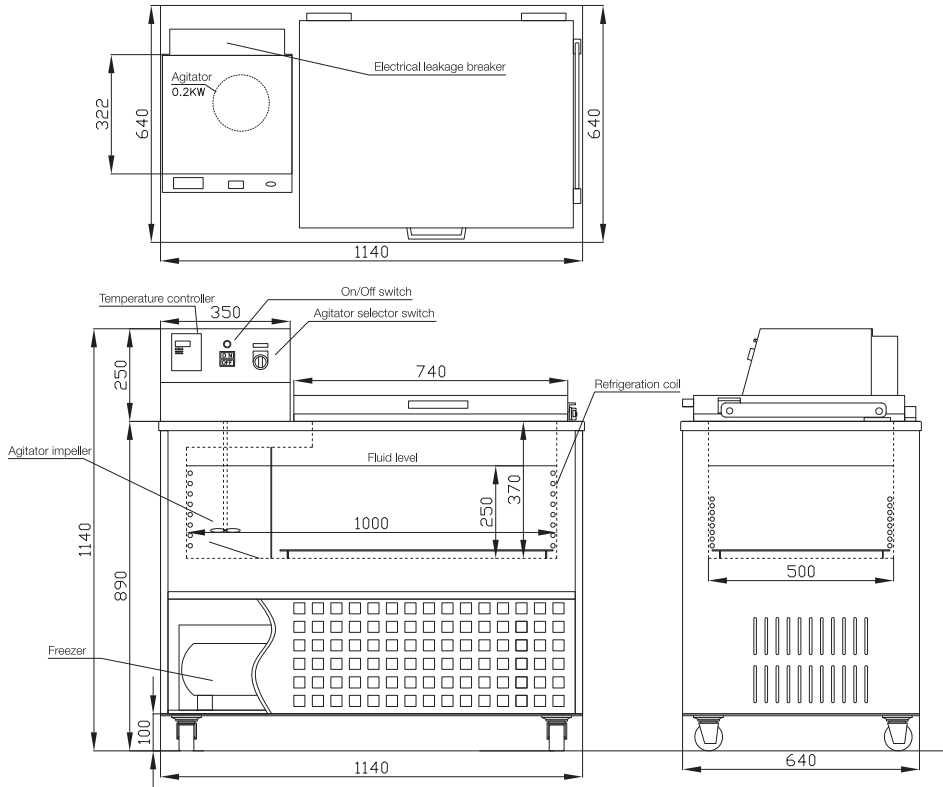

Box dimensions

Box (standard)
Package X 1
Shelves (5) X 1

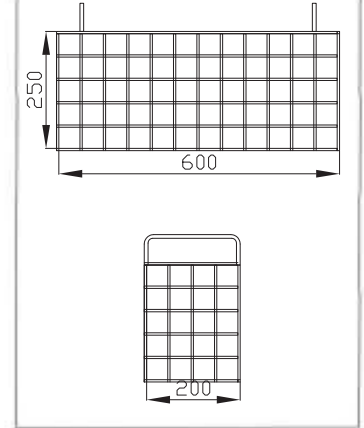

LM-45

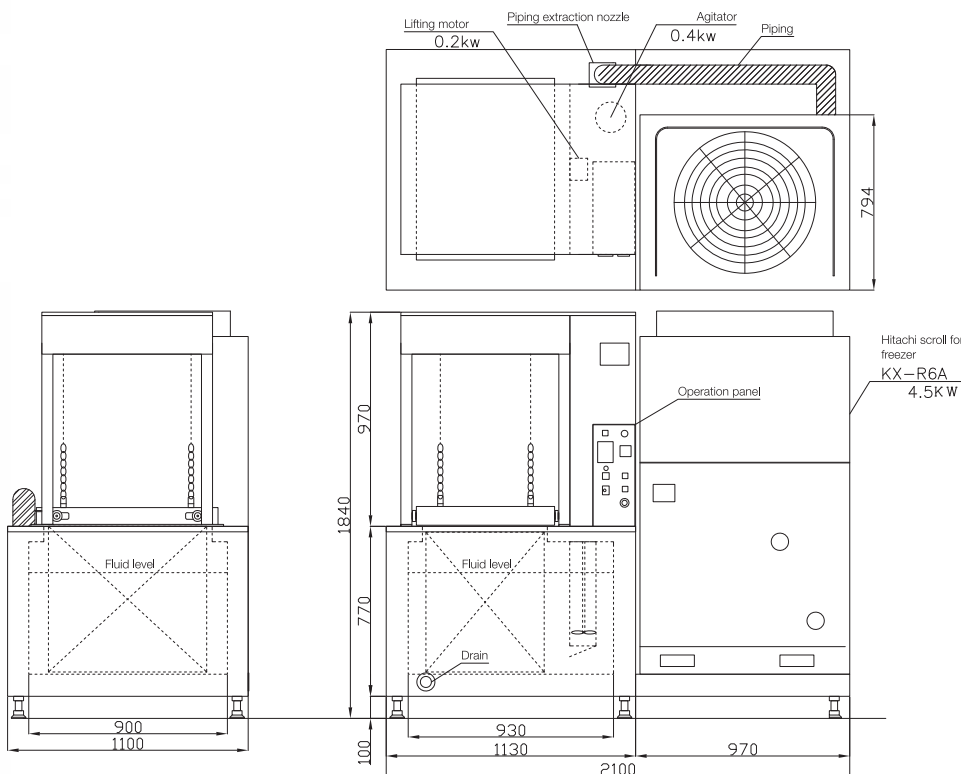

Gondola dimensions

<Front> One shelf: 85mm

Usable space: 72mm

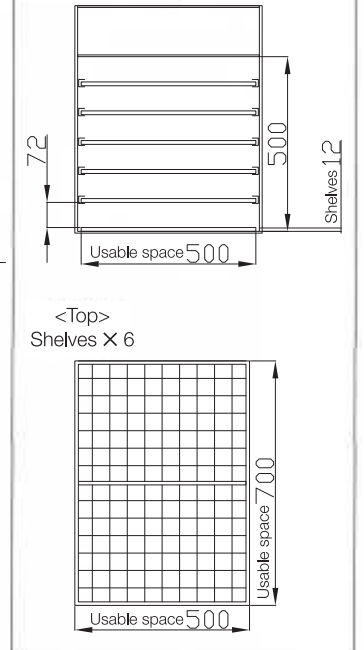

Large type

TLB-1G External Gondola type

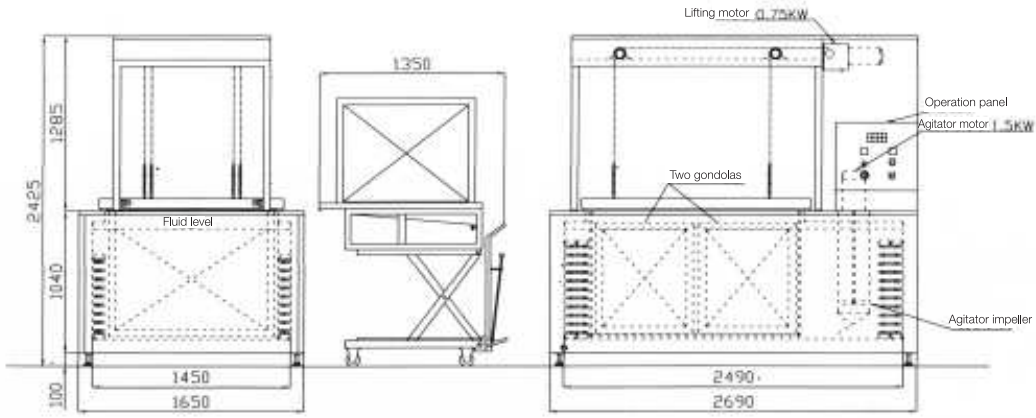

Gondola dimensions

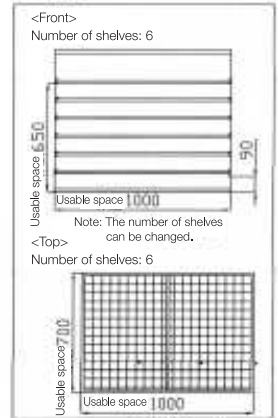

Oversized type

TLB-2G External Gondola type

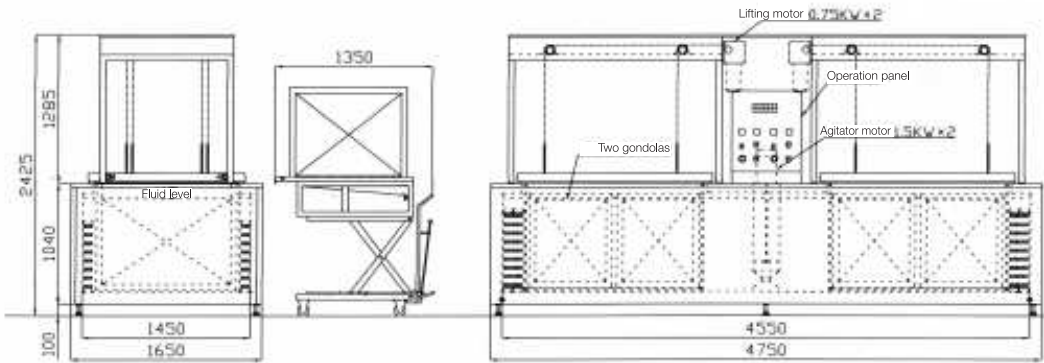

Gondola dimensions

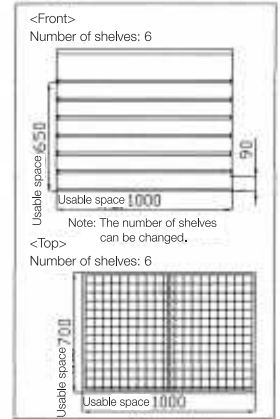

Water extractor

External dimensions

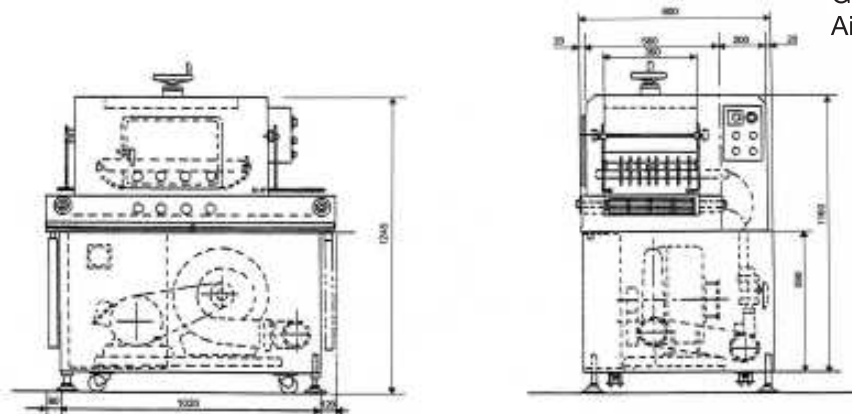

Gondola type
Air 5.5Kw

Patents held by TECHNICAL Co., Ltd.

As a pioneer of the Liquid Freezer, we take pride in providing customers with the best quality products and service in the industry.



U.S. Patents

Registration number: 5222367
Registration number: 5653121



Canadian Patent

Registration number: 2034680



Australian Patent

Registration number: 620270



Chinese Patent

Invention: I 249379



European Patent

Registration number: 0480553



Russian Patent

Registration number: 2005116526



Japanese Patents

Registration number: 2011591
Registration number: 2575321



Company Outline

Company: TECHNICAL CO., LTD.

Established: July 14th, 1989

Address: 3-1-16, Chigasaki-minami, Tuzuki-ku,

Yokohama, JAPAN 224-0037

TEL: 81-45-948-4855 FAX:81-45-948-3660

E-mail: L-freezer@technical.co.jp

URL: <http://www.technical.co.jp>

Main products: TOMIN liquid freezer systems,

Gondola-type freezer,

TUST liquid freezer systems, Defroster,

Water extractors, Disinfectant etc.

Freezing technologies are indispensable for storage and distribution of foodstuffs and other commodities worldwide. The improvement and advancement is of universal benefit and that is why we are constantly striving to provide the best products for our customers.

Liquid freezing may not be appropriate for all foods. However, it does provide unparalleled quality and freshness for all suitable frozen products.

■ Japanese and overseas customers alike accord high ratings to TECHNICAN's TOMIN Liquid Freezers, and sales continue to grow.



Technican Co., Ltd.



Printed using an E3PA Gold Standard environmentally friendly printing method. E3PA: Environment Pollution Prevention Printing Association <http://www.e3pa.com>

